

Welcome to

APM CLIMATE CONTROL SDN BHD

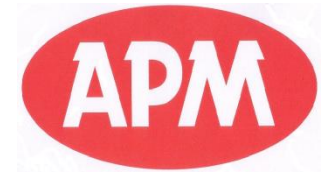

COMPANY PROFILE



- Date of Incorporation** : 19th January 1982
- Major Products** : Air Conditioning Systems & Components , Radiator
- Location** : Lot 600 Pandamaran Industrial Estate
Locked Bag No. 218,
42009 Port Klang
Selangor Darul Ehsan, Malaysia
- Total Land Area** : 22,920 sq meter
- Built-up Area** : 15,700 sq meter
- Technical Licensor** : Calsonic Kansei, Japan
- Production Capacity** : 480,000 units per year
- No. of Employees** : 135

PRODUCT INTRODUCTION

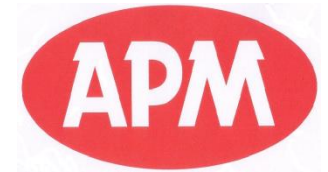

THERE ARE 7 TYPES OF PRODUCTS WHICH APM CLIMATE CONTROL IS CAPABLE OF DESIGNING :

1. AIR CONDITIONERS SYSTEM

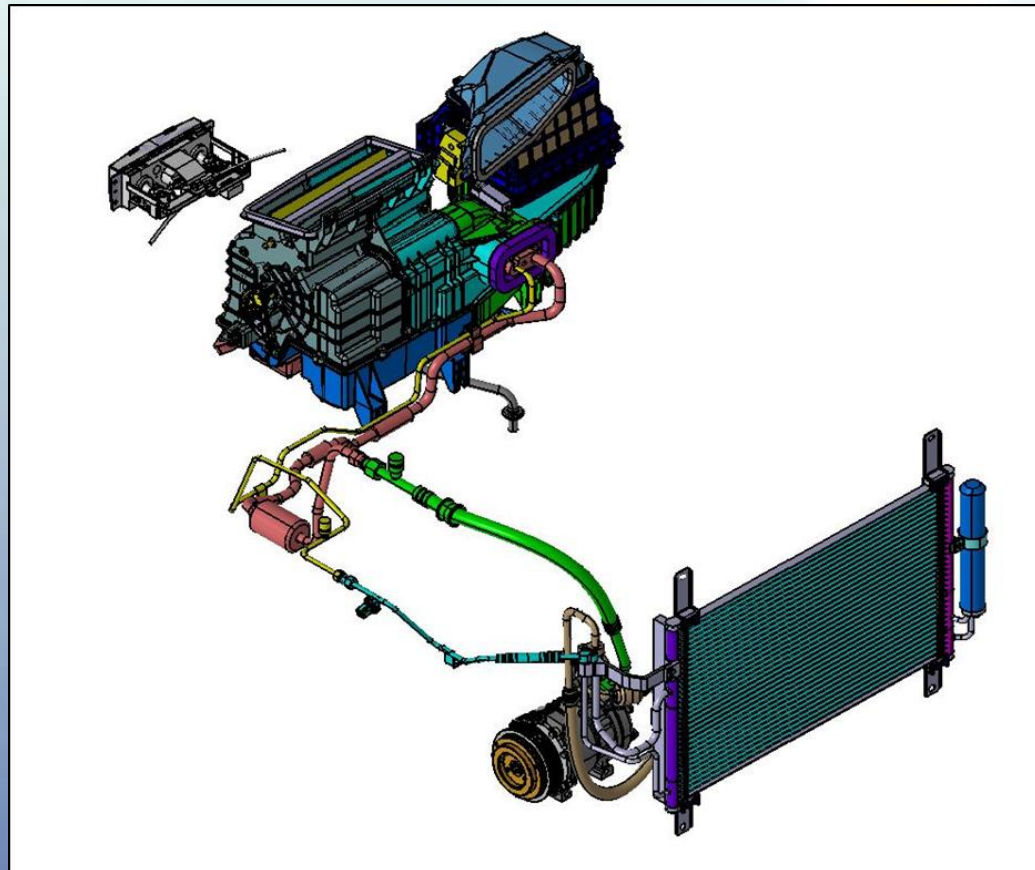

PRODUCT INTRODUCTION

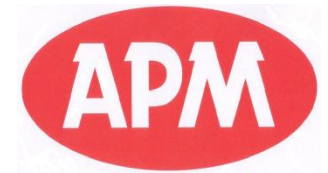

2. COOLING MODULE

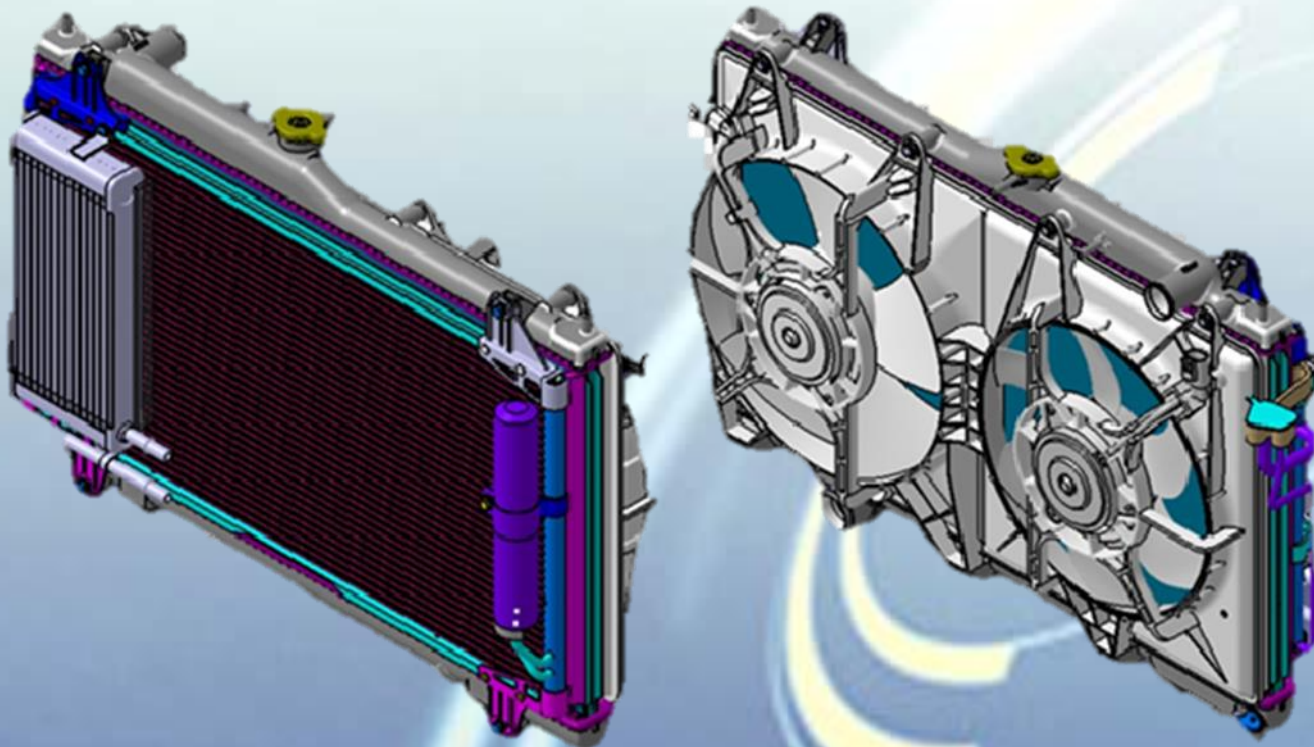

PRODUCT INTRODUCTION

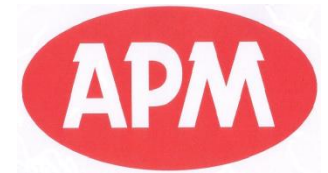

3. RADIATOR



PRODUCT INTRODUCTION

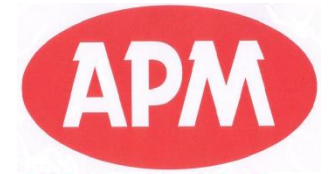

4. PARALLEL FLOW CONDENSER

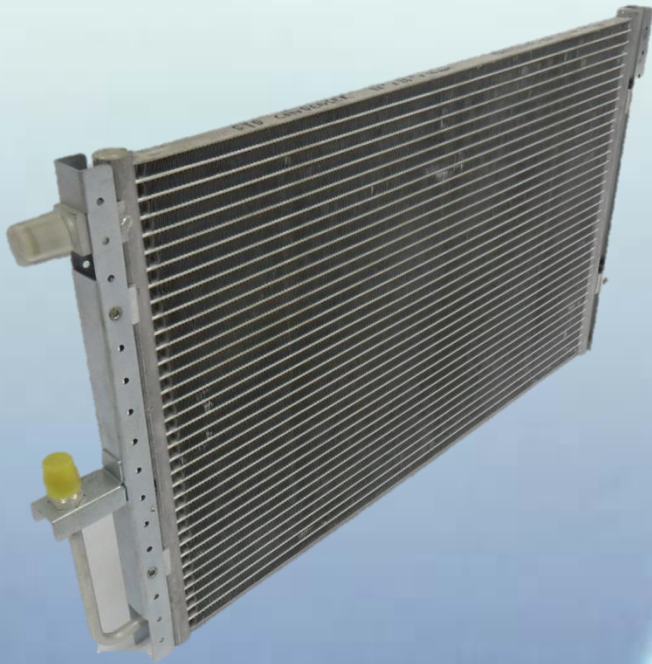

5. SERPENTINE CONDENSER

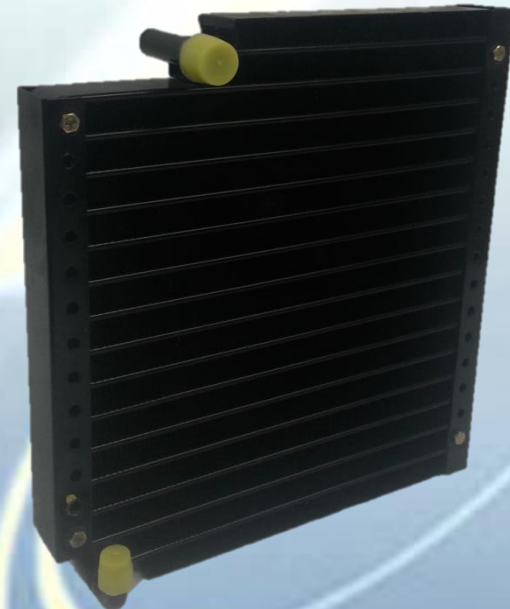

PRODUCT INTRODUCTION

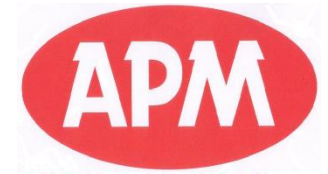

6. PARALLEL FLOW EVAPORATOR



7. SERPENTINE EVAPORATOR



DESIGN & ENGINEERING CAPABILITIES

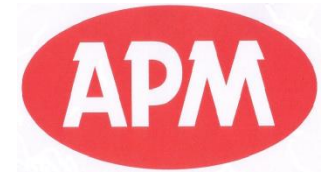

- 1. Engineer : 10 Engineers
- 2. CAD Software : CATIA V5 – 2 units
Solid Work – 6 units
Autocad – 2 units
- 3. CAE Capability : Structure Analysis & CFD Analysis
- 4. Design Method : Computerized Simulation

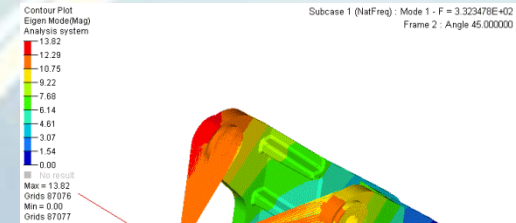
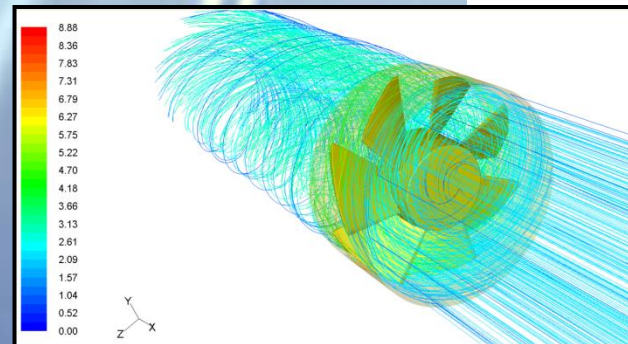
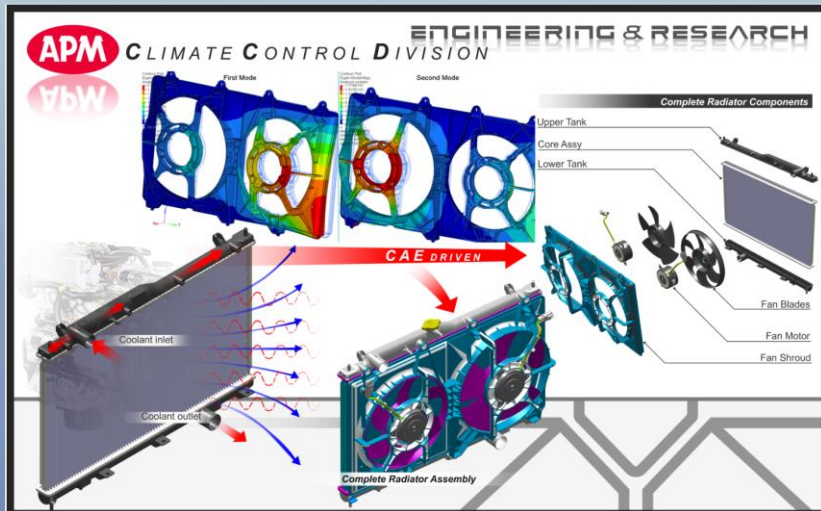

TESTING FACILITIES

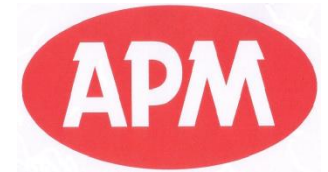

TEST ITEMS

1. PERFORMANCE TEST
 - Radiator Heat Rejection
 - Blower Air flow Performance
 - Condenser Heat Rejection
 - Evaporator Heat Rejection
 - Compressor Cooling Performance
2. VIBRATION TEST
3. PRESSURE REPEATED CYCLE TEST
4. FATIGUE PRESSURE TEST
5. MOTOR FAN BALANCING

EQUIPMENTS

- : PERFORMANCE TEST BENCH
- : VIBRATION MACHINE
- : PRESSURE CYCLE TESTER
- : FATIGUE PRESSURE TEST BENCH
- : BALANCING MACHINE